

TCU08017 Ø8mm Precious Metal Brushes 0.3/1W

| Motor Data | | Part Numbers | |
|--------------------------|------------------|--------------|-------------|
| | | TCU08017P06 | TCU08017P12 |
| Nominal voltage | V | 6 | 12 |
| No load speed | rpm | 13500 | 16000 |
| No load current | mA | 14 | 6 |
| Nominal speed | rpm | 3360 | 5460 |
| Max. continuous torque | mNm | 0.60 | 0.60 |
| Max. continuous current | A | 0.164 | 0.093 |
| Stall torque | mNm | 0.85 | 0.95 |
| Stall current | A | 0.21 | 0.14 |
| Max efficiency | % | 55 | 63 |
| Terminal Resistance | Ohm | 28.0 | 87.0 |
| Terminal Inductance | mH | 0.206 | 0.606 |
| Torque constant | mNm / A | 3.96 | 6.87 |
| Speed constant | rpm / V | 2410 | 1390 |
| Speed/torque gradient | rpm / mNm | 17030 | 17603 |
| Mechanical time constant | ms | 6.60 | 6.82 |
| Rotor inertia | gcm ² | 0.037 | 0.037 |

| Specification | | |
|-------------------------------|----------------|---------|
| Bearing | Sleeve bearing | |
| Max speed | rpm | 18000 |
| Axial play | mm | ≤0.3 |
| Number of commutator segments | 5 | |
| Ambient temperature | ° C | -20~+65 |
| Max winding temperature | ° C | 100 |
| Thermal resistance | | |
| Housing - Ambient | ° C/ W | 52.8 |
| Winding - Housing | ° C/ W | 26.4 |
| Thermal time constant | | |
| Motor | s | 21 |
| Winding | s | 2.37 |
| Number of pole pairs | 1 | |
| Weight | g | 4.5 |

Combination

Gearbox
 PG08C
 Ø8mm 0.1 Nm 16:1-1024:1
 Page 41

Operating Range

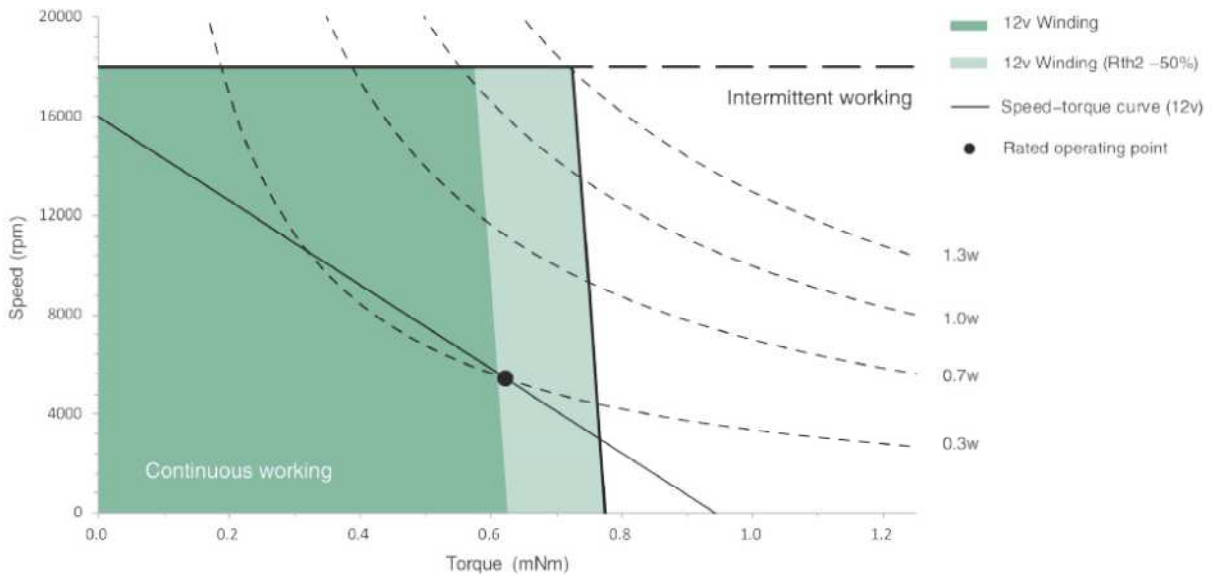

Dimension

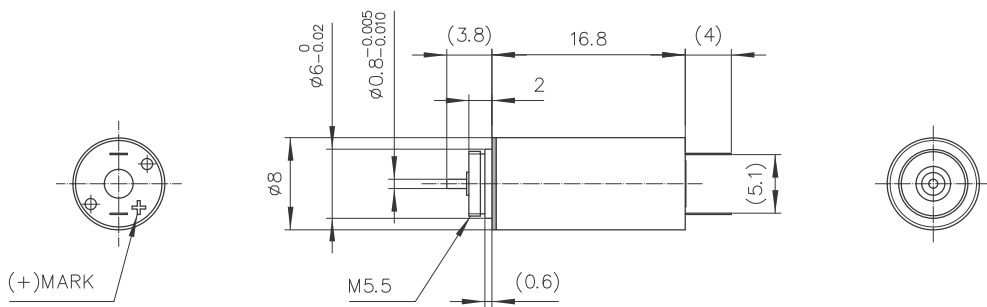

TCU08017Pxx-S001